



RAINWATER HARVESTING

BETA SUBMERSIBLE GARDEN PUMPS

- Multi-stage submersible pumps in stainless steel & polyethylene
- Excellent for irrigation use
- In-built flow controller
- In-built non-return valve
- Automatic dry-run protection
- Maximum head 48m
- Maximum flow 95 l/m
- Direct suction, 1" nozzle or 1" bsp male inlet
- 1" bsp female outlet
- 3m lifting cord
- 15m cable

Submersible pumps for the delivery of clean water for garden and landscape use.

Intelligent built-in controller senses the water requirement and electronically switches the pump on and off.

Guaranteed protection against dry running.

The Beta 1000 model is particularly suitable for smaller tanks.

The 1200 model has alternative inlet fittings for the connection of fixed or floating suction filters in larger tanks.



Beta 1000 / 1200 submersible pumps with direct suction inlet.

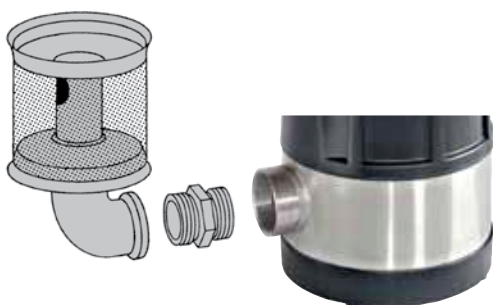
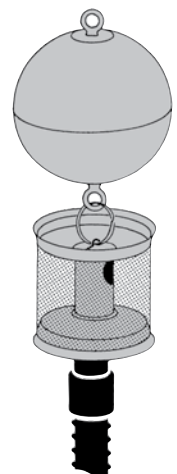

Beta 1200X

BSP connection for Fixed fine suction filter



Beta 1200T

Hose nozzle for Floating fine suction filter