

ASPRI PUMPS

- **Sturdy construction in AISI 304 stainless steel.**
- **A range of three models to meet individual capacity and pressure requirements.**
- **Available as bare pumps or with integral automatic controller.**
- **All metallic parts in contact with water are in stainless steel.**
- **Exceptionally quiet running.**
- **Built-in dirt strainer**
- **Ideal for rainwater harvesting and pressure boosting.**

The Aspri range of pumps from ESPA are high quality horizontal multi-stage units with a robust yet compact construction.

Available in three versions suitable for a range of domestic and commercial applications, and can be supplied with automatic fixed speed controller, variable speed inverter control or as a bare pump.

We can also supply control panels for single or dual pump operation.

Three-phase versions are available on request.



Flexible System Design

Our comprehensive range of specialist items has been developed specifically for rainwater harvesting systems. Because the range consists of separate components, it has exceptional flexibility.

These items are suitable for almost any system design, whether you're planning a system for a small house, school or large industrial or commercial premises.

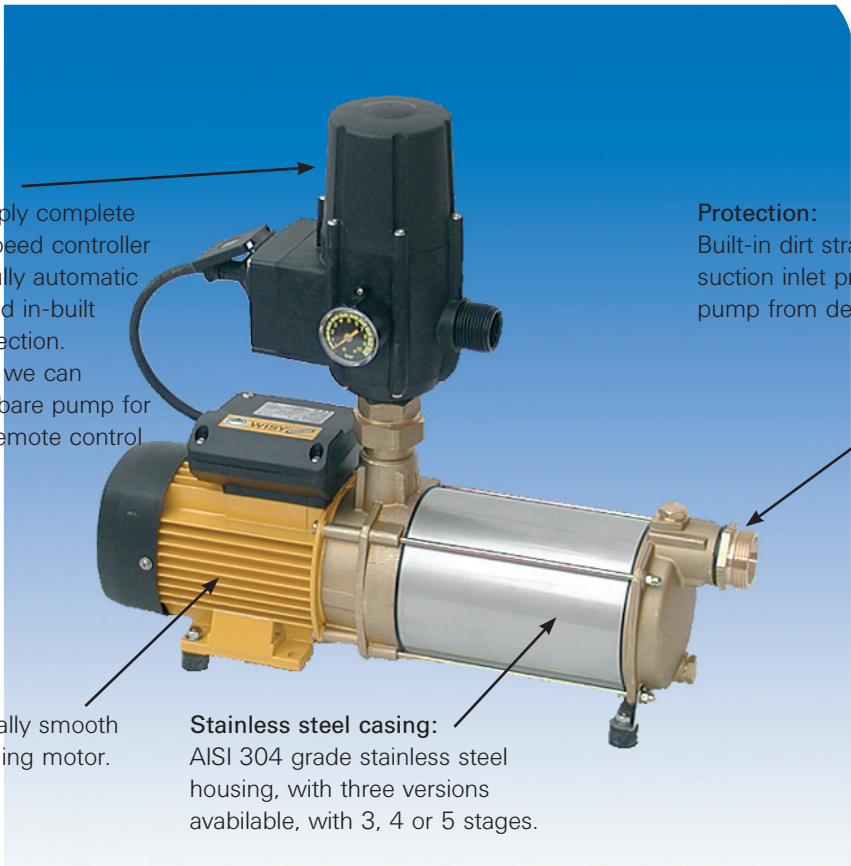

Controller:

We can supply complete with fixed speed controller to provide fully automatic operation and in-built dry-run protection. Alternatively we can supply as a bare pump for use with a remote control panel.

Motor:

Exceptionally smooth quiet running motor.

Stainless steel casing:

AISI 304 grade stainless steel housing, with three versions available, with 3, 4 or 5 stages.

Protection:

Built-in dirt strainer on the suction inlet protects the pump from debris.

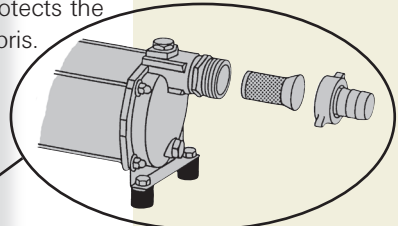

We are the UK's sole supplier of Wisy products for rainwater utilisation

Aspri pump with Controlmatic automatic controller

Accessories for Aspri pumps

If required we can supply a stainless steel wall bracket designed to carry the Aspri pumps. This is supplied complete with rubber mounts for vibration elimination and noise reduction holding the pump firmly in place. An optional hose assembly is also available for the outlet connection. This is a flexible hose with braided steel covering and is complete with bsp connections at both ends and an isolating ball valve. This is designed to eliminate vibration to the connecting pipework.



On request we can supply Aspri pumps in three phase versions for use with variable speed inverter control units. Variable speed gives improved energy efficiency, better performance and 'soft start' operation to eliminate water hammer problems.

Model	kw	no. of impellers	H max (m)	Q Max (l/m)	Inlet size	Outlet size
Aspri 15-3	0.37	3	33	60	1"	1"
Aspri 15-4	0.55	4	44	60	1"	1"
Aspri 15-5	0.75	5	53	60	1"	1"

Aspri pumps - 15 Series

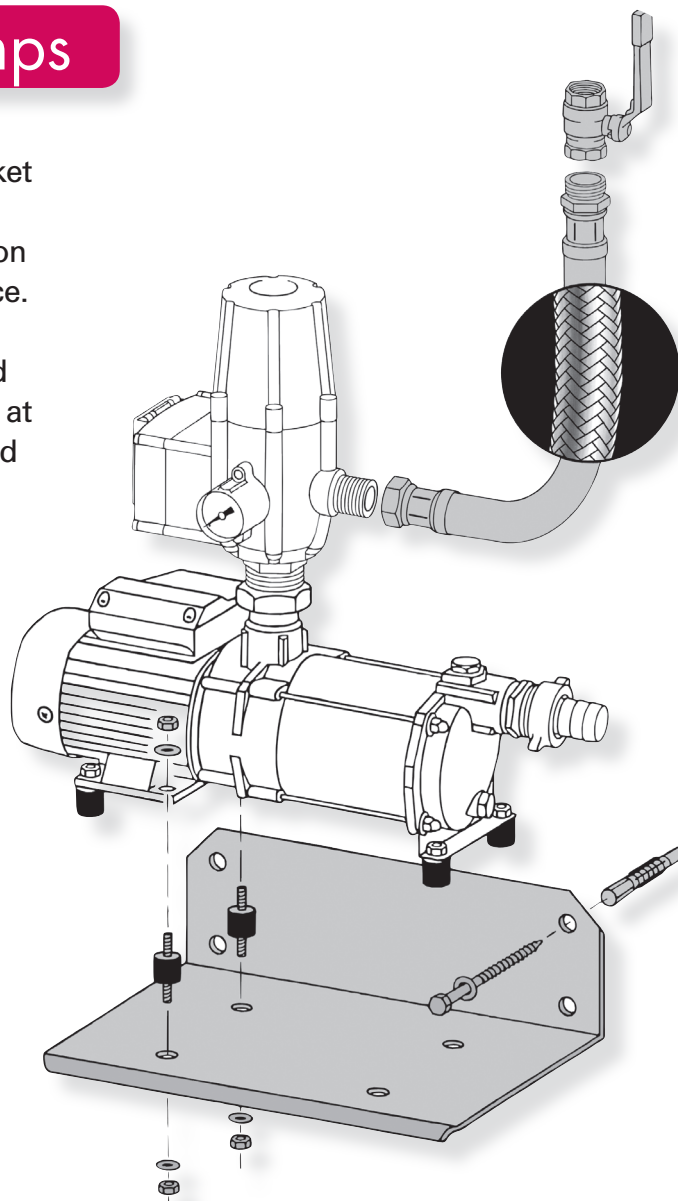
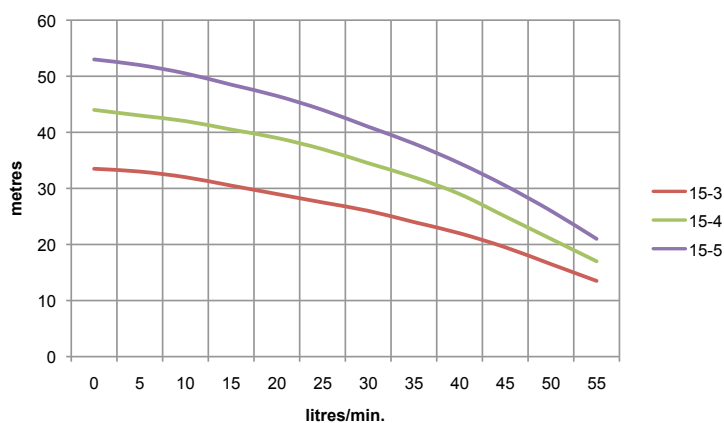

Aspri pump and controller with optional wall bracket and outlet hose assembly

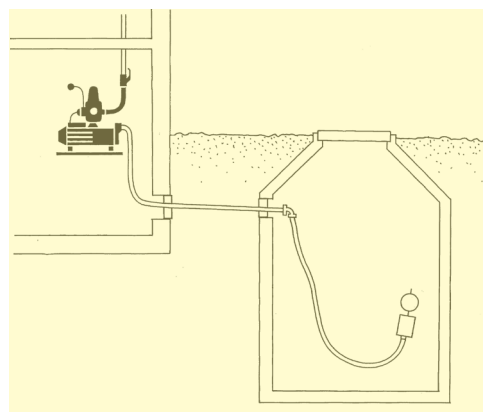

Distributor:

Rainharvesting Systems Ltd.

The Green Shop
 Calf Way, Bisley,
 Stroud, Gloucestershire GL6 7BX
 Tel: 0845 223 5430
 Fax: 01452 772008
 E-mail: sales@rainharvesting.co.uk
 Website: www.rainharvesting.co.uk