

# VORTEX FILTER - type WFF150

- Suitable for roof areas up to 500m<sup>2</sup>
- Connects to standard storm water pipes below ground
- Virtually all debris, moss, leaves, insects, etc. is washed through the uniquely constructed vertical filter by self-cleaning action
- Unique oxygen-enriching function
- No restriction or obstruction of water flow through the appliance (conforms to DIN1986)
- More than 95% efficient
- Minimum maintenance
- Tough polyethylene housing
- High quality stainless steel filter mesh
- 50cm extension tube can be trimmed to length to suit invert level
- Can also be wall-mounted

## UNIQUE FEATURES OF THE VORTEX FILTER:

- Vortex filters have a vertical filter mesh. This makes the filter insert virtually self-cleaning by the action of water flowing over the it. As debris enters the chamber, it simply drops or gets washed off by the incoming water.
- The action of water passing through the vertical mesh oxygenates as it flows. This has the effect of saturating the water with air as it passes to the tank, thus enhancing the quality of the water.
- There are no restrictions or obstructions on which debris can collect. The full cross-section of the rainwater drainage system is maintained right through the filter, so that excess rainwater is led directly to the storm drains or soakaway. This is especially important in hail storms and torrential rainfall. Even in such extreme cases much of the filtered water is transferred to the storage tank.

WFF filters can be used where rainwater from the roof is channelled through a horizontal underground pipe. The unit filters and diverts rainwater to a storage tank or cistern. Leaves, moss and other debris are washed through to drain or soakaway.

Rainwater enters the inlet connection in the side of the WFF unit. The inlet is designed to swirl the water in a vortex-like action around the surface of the stainless steel filter below. The rainwater is drawn through the vertical mesh walls of the fine filter by adhesion, then collected and fed through the outlet to the storage tank. Debris and particles too large for the filter are flushed through to the drain outlet by the action of water flowing down the surface of the filter. More than 95% of the rainwater entering the WFF is filtered and collected by this principle, .

Pitched roofs of slate, clay or concrete are the most suitable for collecting rainwater. Flat roofs can also be utilised but the volume of water collected is reduced. Planted roof areas or thatch are less suitable due to the low collection efficiency and discolouration of the collected water.



**larger units are available to suit commercial and industrial applications**



We are the UK's sole supplier of Wisy products for rainwater utilisation



Products shown with this logo are included on the Water Technologies List making them eligible for Enhanced Capital Allowance.

Data Sheet WF/14/02

# VORTEX FILTER - type WFF150

## The WFF-150 unit:

- Polypropylene housing
- Stainless steel filter insert
- Rainwater inlet DN 150 (160mm pipe)
- Storage tank outlet DN 100 (110mm pipe)
- Drain outlet DN 150 (160mm pipe)
- Inlet and both outlets can rotate through 360°
- 0.44mm or 0.28 mm mesh versions
- Supplied with 50cm extension tube and 30cm lifting handle

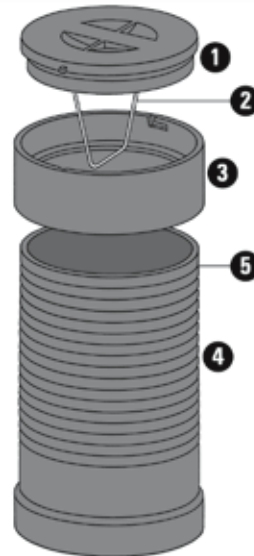

## WFF FILTER Accessories

### 50cm extension tube

For installations where the filter connects to a deep storm drain additional extension tubes are available. Easily cut to length due to the moulded-in parallel lines.

### Extended filter handles

For use where one or more full length extension tubes are used. The longer handles enable easy removal of the filter insert for cleaning purposes. Available in 63cm and 100cm lengths.

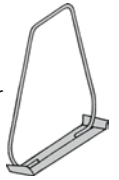

### Stainless-steel wall bracket

For mounting the unit to a wall, where the filter is used internally or is supplying an above-ground tank



### Stainless-steel strainer basket

Fits inside the WFF filter to prevent debris from passing to waste. Requires regular inspection to empty the contents.



### Blind Insert

For maintenance purposes, a blind insert is available. This can be used in place of the filter insert to divert all flow to the soakaway.



## WFF filter components

- 1 - Lid
- 2 - Filter removal handle
- 3 - Upper ring
- 4 - Extension tube
- 5 - Parallel cutting lines
- 6 - Filter insert
- 7 - Rainwater inlet
- 8 - Clean water outlet
- 9 - drain outlet

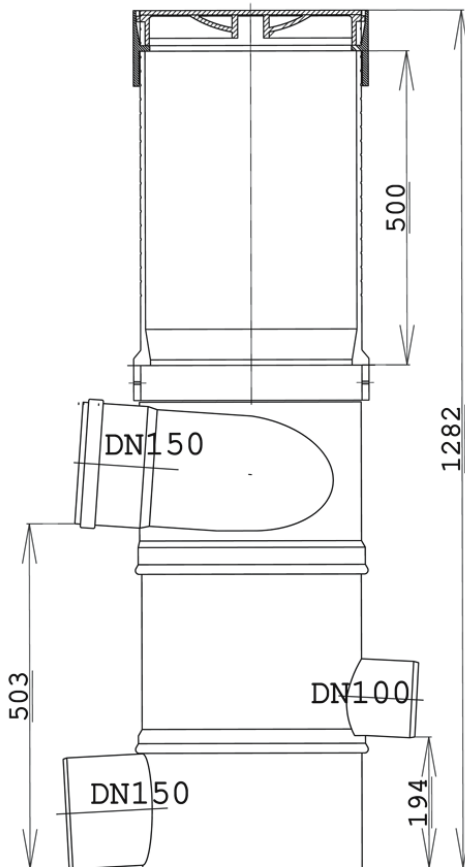
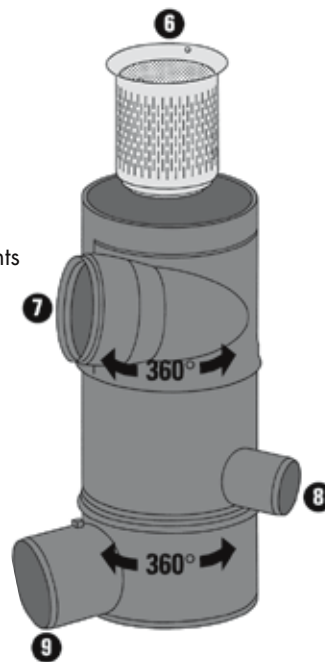

Dimensions of the Vortex filter unit with extension tube fitted. Note the tube can easily be cut to length to suit invert depth.

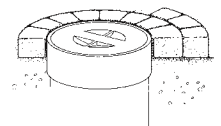
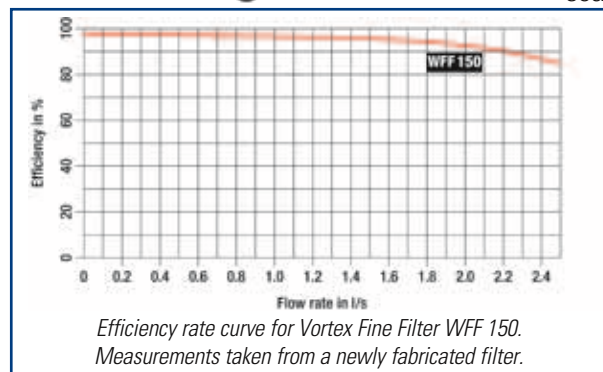

Paving can be laid around the end ring. The lid simply twists to remove.



Distributor:

## Rainharvesting Systems Ltd.

The Green Shop  
Calf Way, Bisley,  
Stroud, Gloucestershire GL6 7BX  
Tel: 01452 772000  
Fax: 01452 772008  
E-mail: sales@rainharvesting.co.uk  
Website: www.rainharvesting.co.uk