

RAINTECH® RAINWATER STORAGE TANKS

- Designed specifically for use in rainwater harvesting systems
- UK manufactured to BS 4994
- One-piece GRP underground tanks in a wide range of sizes
- Calmed inlet, pump platform and overflow trap pre-fitted
- Complete with secure access cover and frame
- Lightweight and easy to handle
- Bespoke options available
- Delivery anywhere mainland UK

RainTech® GRP 'submarine' tanks for underground installation are manufactured in the UK to BS 4994 and are available in a variety of sizes to suit most domestic and commercial needs.



RainTech® tanks are designed specifically for use in rainwater harvesting systems, with in-built flow calmer, pump platform and overflow unit.

Our tanks are supplied pre-fitted with a unique anti-surge device which provides secure and effective protection.

The British Standard for Rainwater Harvesting BS 8515:2009 states that all rainwater tanks must be protected against back-flow from the storm drain.

The vertical shaft can be trimmed on site to suit invert levels. Tanks are supplied complete with a pump platform directly below the shaft and a pedestrian-duty inspection cover.

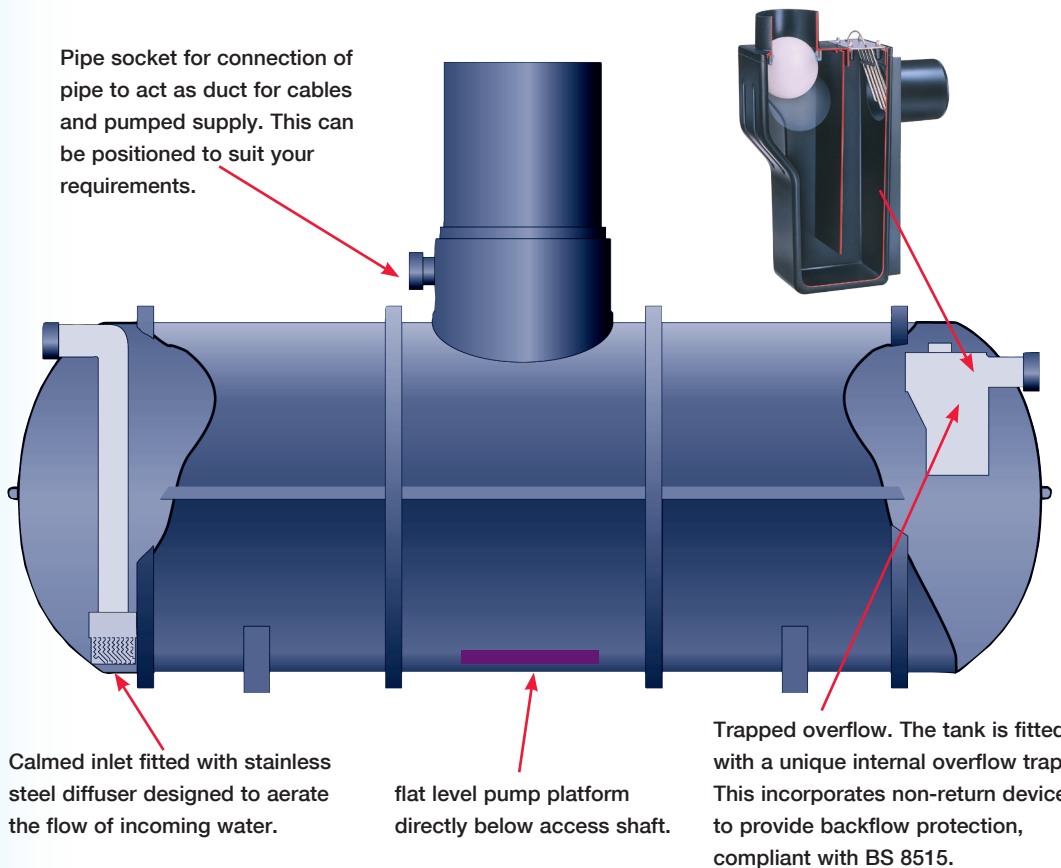

RAINHARVESTING SYSTEMS



Commercial Rainwater Harvesting

- Schools
- Offices
- Industrial
- Agriculture
- Horticulture
- Vehicle wash

Flexible System Design

Our comprehensive RainTech® range of specialist products has been developed specifically for use in Rainwater Harvesting Systems. The exceptional flexibility of our products enables us to design a system for almost any application.

With years of experience and our in-depth product knowledge, we can provide the right solution to suit your requirements backed up by excellent technical support.



We are the UK's sole agent & distributor of Wisy® products for rainwater utilisation



UKRMA founder member

RAINTECH® TANKS FOR COMMERCIAL / INDUSTRIAL USE

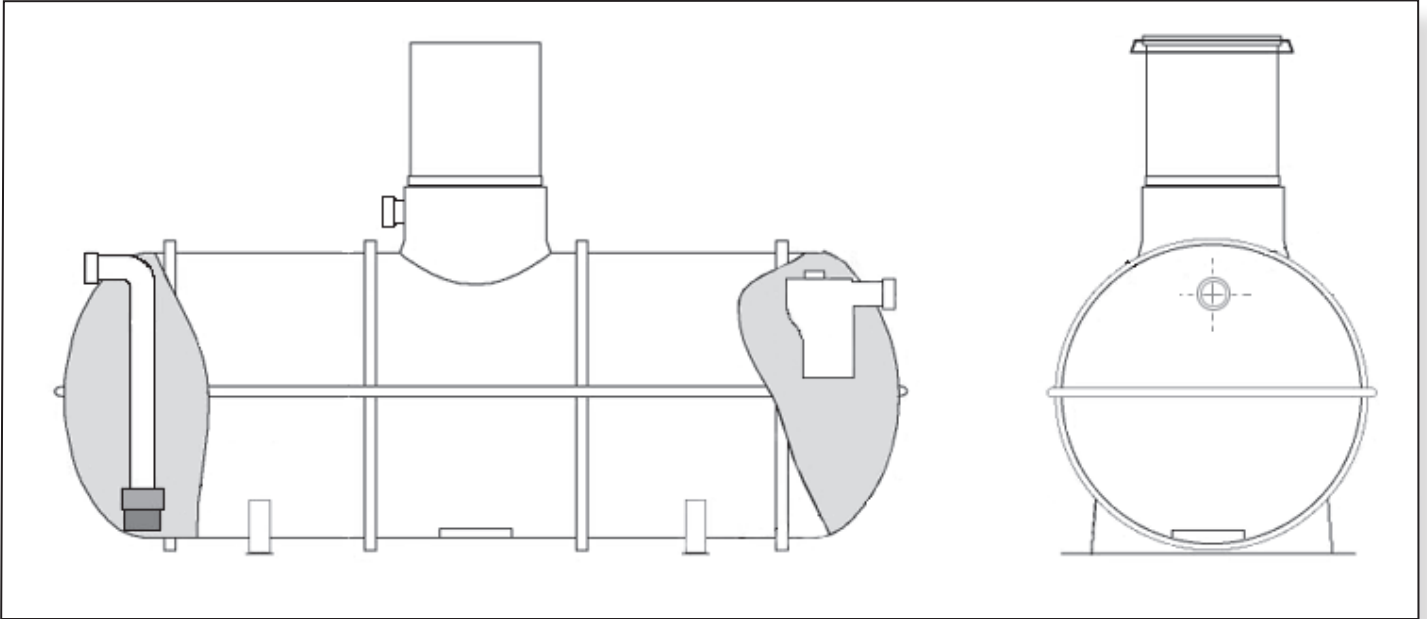

NOMINAL VOLUME (litres)	7500	10,000	12,000	16,000	18,000	22,000	26,000	34,000	38,000	46,000	54,000
NOMINAL DIAMETER (mm)	1840	1840	1840	1840	2620	2620	2620	2600	2620	2620	2620
NOMINAL LENGTH (mm)	3350	4450	5250	6900	4350	5100	5850	7380	8150	9680	11220

Other sizes and specials available on request.

The tank is illustrated in its standard layout, with inlet and overflow pipes at opposite ends and the duct connection in the shaft facing the same direction as the inlet.

Different layouts can be arranged when ordering to suit individual requirements. Other sizes can also be accommodated and additional connections and access shafts can also be fitted at time of manufacture if required.

Please call us if you need further information or if you wish to discuss particular requirements.



Tanks can be supplied suitable for either concrete or granular backfill, ground conditions permitting. All tanks must be installed on a 300mm concrete base.

If subject to vehicular traffic a heavy duty inspection cover should be used in place of the standard pedestrian duty one supplied and a reinforced slab should be cast over the tank.

All tanks are built to order and as such are subject to a lead time of approximately 3-4 weeks.

Please note that tanks are delivered on a flat-bed vehicle unless otherwise arranged and off-loading is the responsibility of the customer.



Distributor:

Rainharvesting Systems Ltd.

The Green Shop, Calf Way,

Bisley, Stroud,

Gloucestershire GL6 7BX

Tel: 01452 772000

Fax: 01452 772008

E-mail: sales@rainharvesting.co.uk

Website: www.rainharvesting.co.uk