

WISY 'FS' DOWNPIPE FILTERS

- ◆ Suitable for roof areas up to 200m²
- ◆ Compact design with 0.28mm filtration. (0.44mm also available)
- ◆ 5 year guarantee
- ◆ Full cross-section of the downpipe is maintained right through the filter. Zero restriction of drainage flow
- ◆ Stainless steel construction, resistant to corrosion and frost.
- ◆ Simple to fit and maintain
- ◆ Easily cleaned, dishwasher safe
- ◆ High efficiency, high reliability
- ◆ Manufactured in Germany by Wisy®
- ◆ Available in 6 sizes to fit most UK and EU round pipes
- ◆ Also available in Copper housing



These filter collectors are designed for simple and easy installation in standard round-section rainwater downpipes. The filter is installed by removing a section of downpipe. Once fitted the filter is capable of collecting over 95% of the water passing through it.

The Wisy FS filter is of the highest quality



and is typical of fine German engineering. With no obstruction or narrowing of the downpipe, the unique design of the filter (WISY Patent No 3812136) maintains a full flow of water through the downpipe. This is particularly important in hailstorms and torrential rainfall. Even in such demanding weather conditions, the FS filter will harvest 50% or more of the rainwater flowing through the downpipe. Debris and excess water is piped in the conventional manner to surface water drain or soakaway.

Downpipe filters are particularly suitable where water is to be stored in above ground tanks. A larger version (the 'standpipe' filter) is also designed to fit a downpipe, but has the outlet below ground level.

In order to maintain efficiency the filter insert requires simple cleaning at regular intervals, but will never need replacing.

Available to fit 68mm, 76mm, 80mm, 87mm, 100mm and 110mm round pipes.



Flexible System Design

Our comprehensive range of specialist items has been developed specifically for rainwater harvesting systems. Because our range consists of separate components, it has exceptional flexibility.

We stock equipment suitable for almost any system design, whether you're planning a system for a small house or a large housing development.

A wealth of experience

We have been supplying rainwater harvesting systems throughout the UK since 1995 and have accumulated vast experience in this specialist field. With our large stocks of equipment and our excellent technical expertise, we offer an unrivalled level of service to our clients.



We are founder members of the UK Rainwater Management Association.



We are the UK's sole agent and distributor of Wisy products for rainwater utilisation.

Data sheet FS/14/01

Wisyr® Downpipe Filters

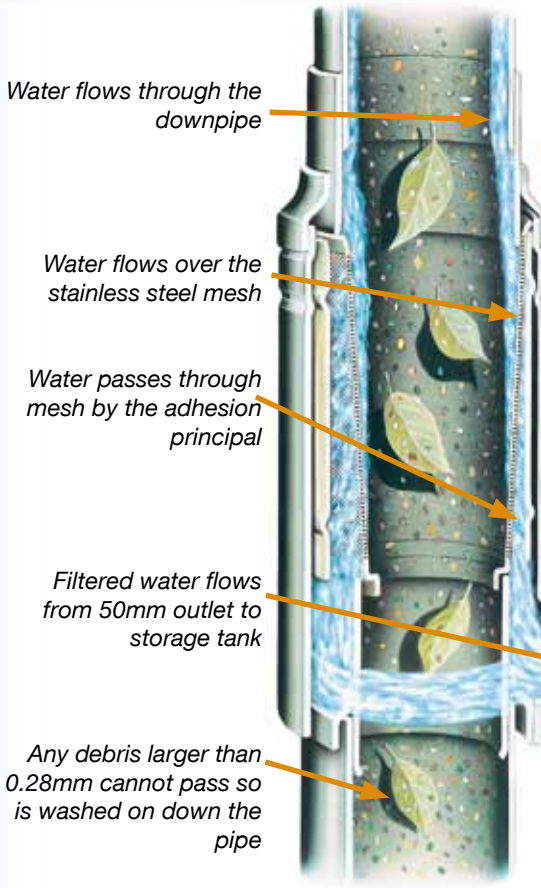

Wisyr® rainwater filters are quite simply unique. There are no other filters that operate by the same principle, nor give the same performance with such fine filtration. Corrosion proof, with no moving parts and nothing to wear out, means that once fitted there are no ongoing costs.

Our confidence in the quality of the product is reflected by a 5-year guarantee on all Wisyr® filters. The operating principle is simple and elegant; water has a natural adhesive quality; it will 'stick' to and flow across a smooth surface (like a window), particularly when the surface is vertical.

By exploiting this quality, water is drawn through the vertical stainless steel mesh. Filtered water passes into the collection

channel and flows via the outlet connection to the storage tank. Remaining water washes debris and particles larger than 0.28 mm through the centre of the filter collector into the drain or soakaway in the normal manner.

Maintenance is simply a matter of removing the stainless steel mesh element and cleaning about every three months.

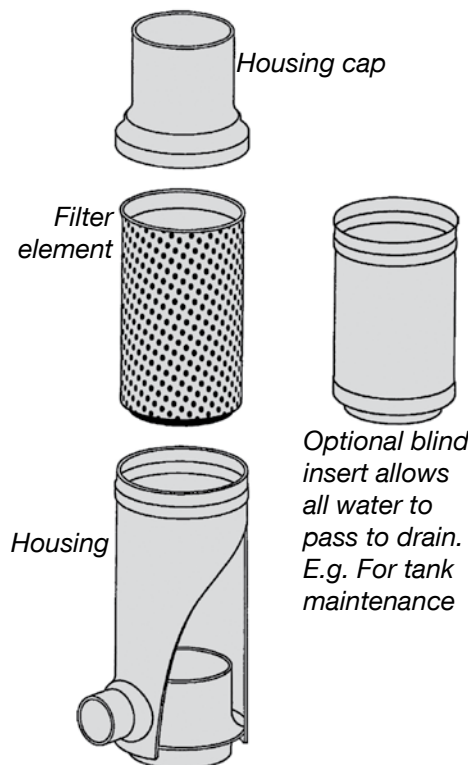
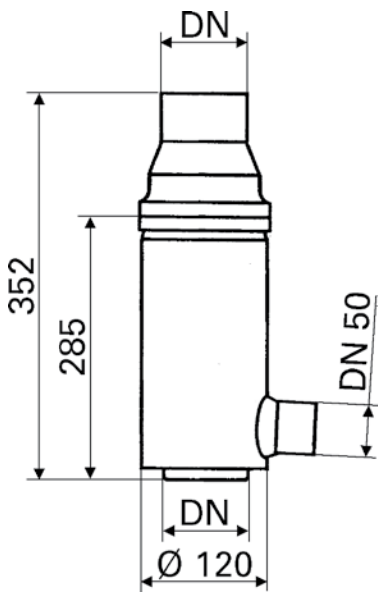

RAINHARVESTING SYSTEMS Ltd.
BISLEY, GLOS.
 01452 772000
www.rainharvesting.co.uk



Private housing



Social housing



Gardens



Agriculture



Industrial



Commercial